



DSD-Dostál, a.s.





DSD-Dostál, a. s.

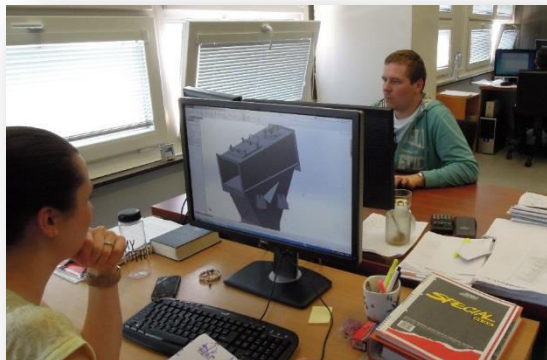

Náš tým

- Engineering
- Výroba

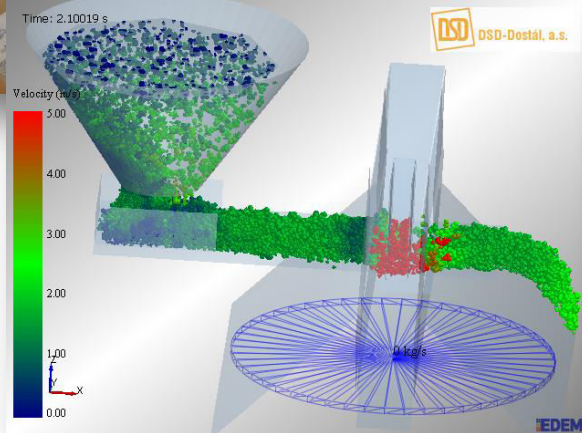



Současný stav expedice



Příklady stávající situace nakládky



Současný stav expedice

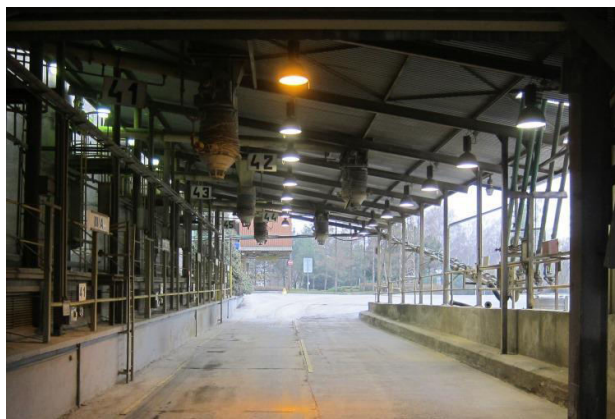

Příklady stávající situace nakládky



Nezbytná legislativa

ČSN EN ISO 14122-3
Bezpečnost strojních zařízení – trvalé prostředky
přístupu ke strojním zařízením

ČSN 74 3305
Ochranná zábradlí

ČSN EN 13374
Systémy dočasné ochrany volného okraje

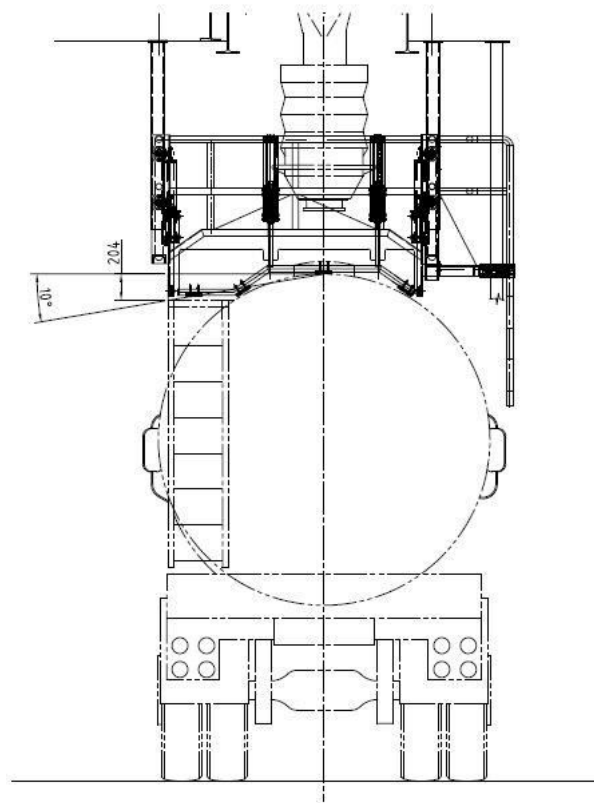



Nezbytná legislativa

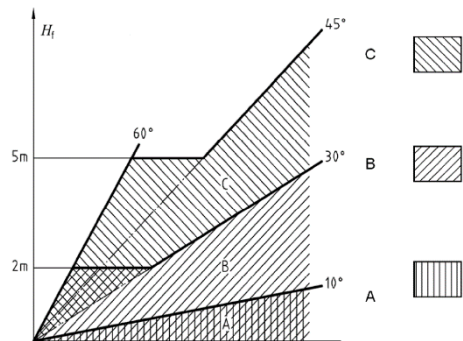

Třídy pro použití při různých sklonech a výškách pádu

Rozměry pro výšku a rozteče u dílců ochrany volného okraje

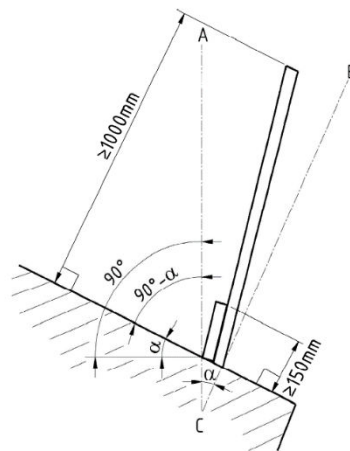
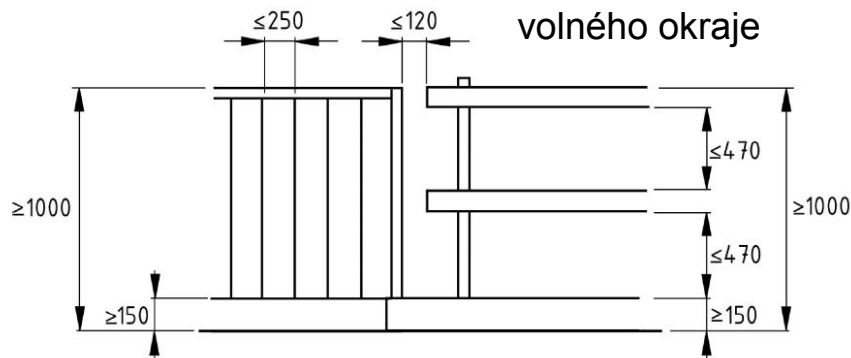

Sklon systému ochrany volného okraje

Zkušební zařízení pro nárazovou zkoušku ochrany volného okraje třídy B

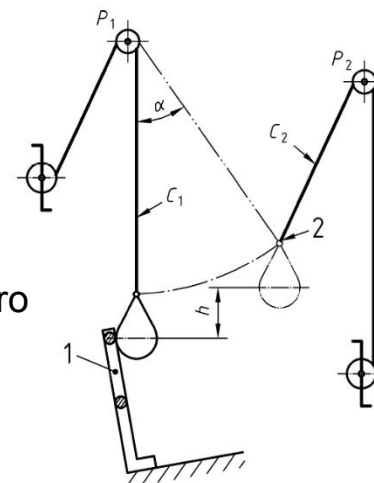



Řešení situace



Rozhodnutí



Obsluha jednoho plnicího místa

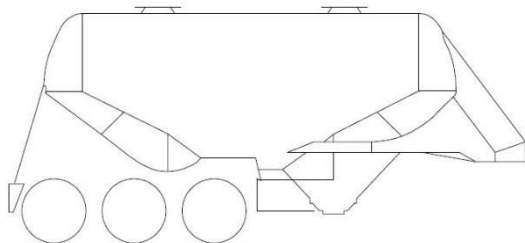
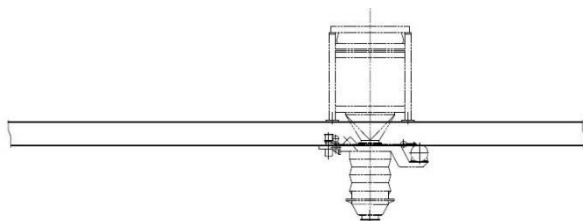

Obsluha více plnicích míst

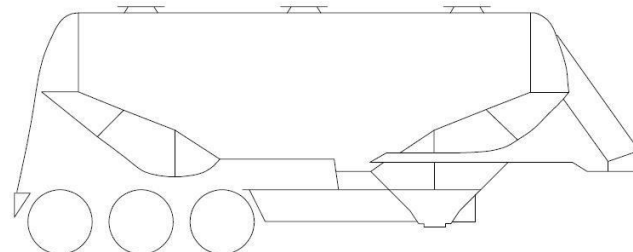
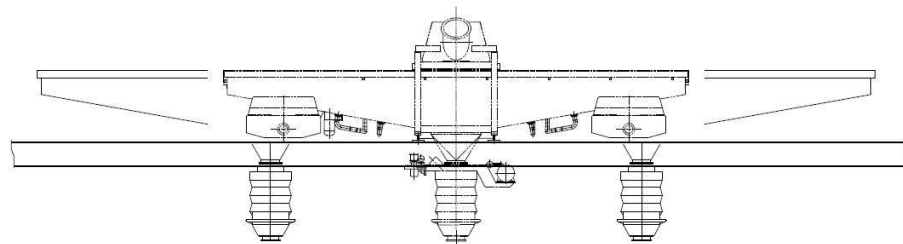



Jedno plnicí místo



Jednoduché bezpečnostní zábradlí

Možnosti ovládání:

- ruční
- pneumatické
- motorické

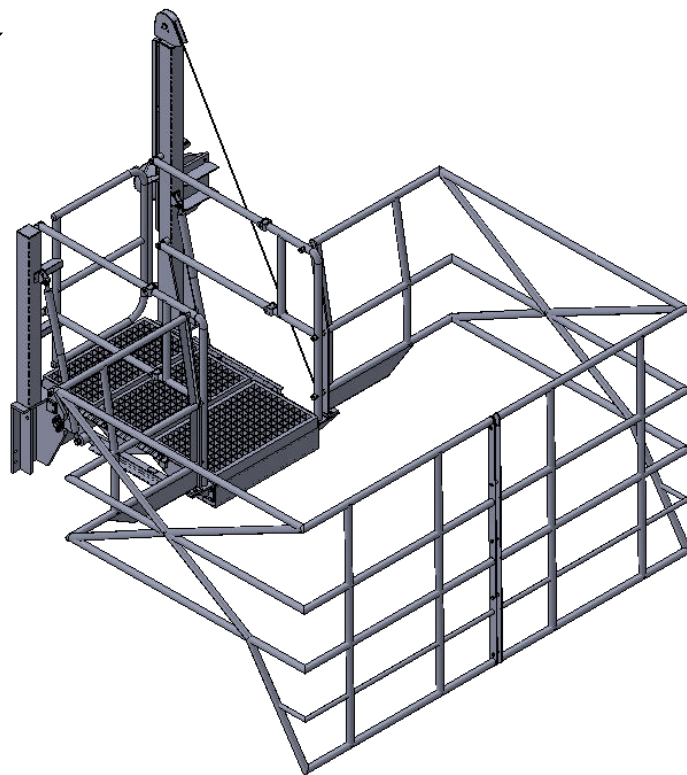
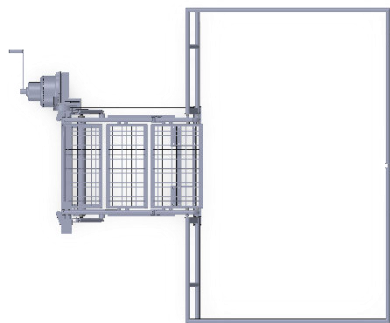



Více plnicích míst



Bezpečnostní zábradlí

Možnosti ovládání:

- pneumatické
- motorické

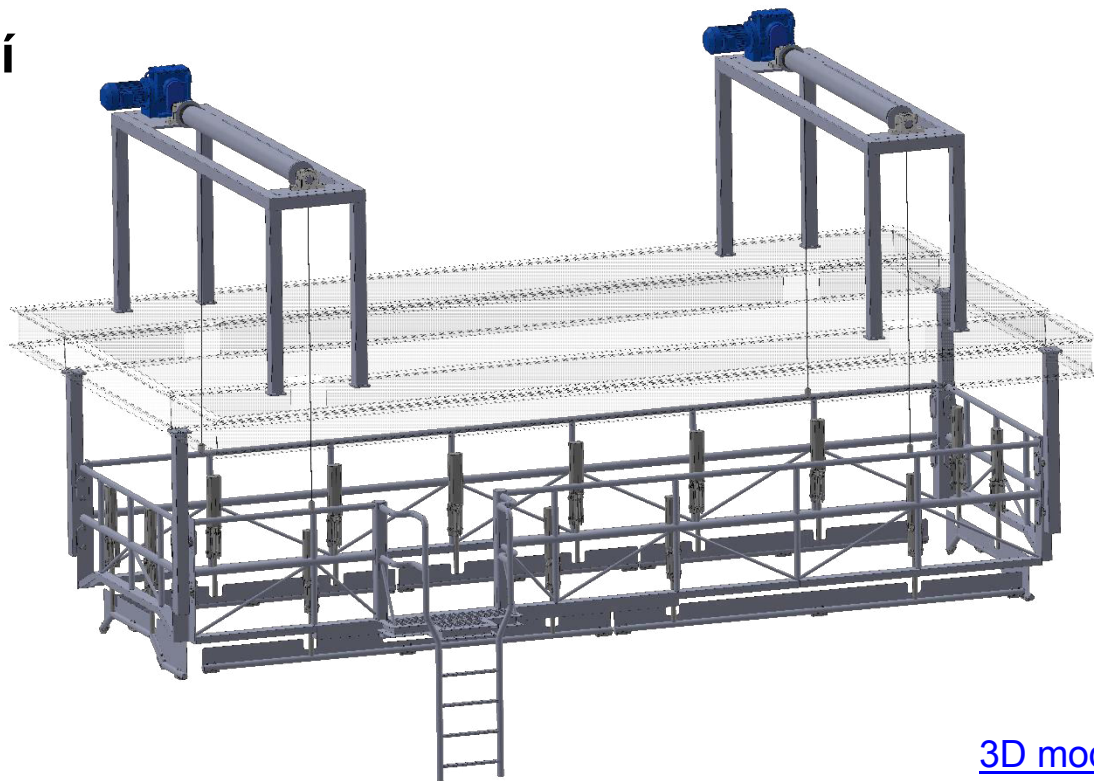
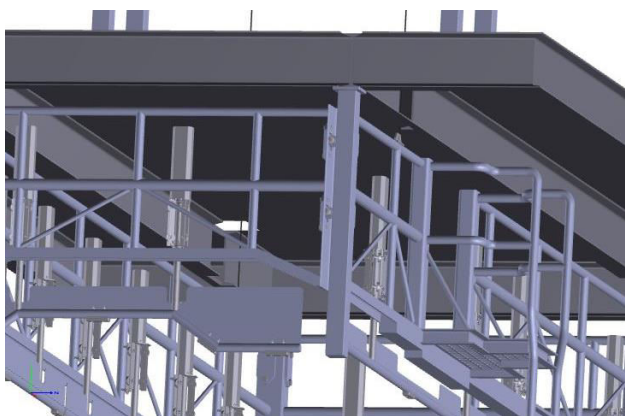

[3D model](#)



Provedení



Pracovní poloha

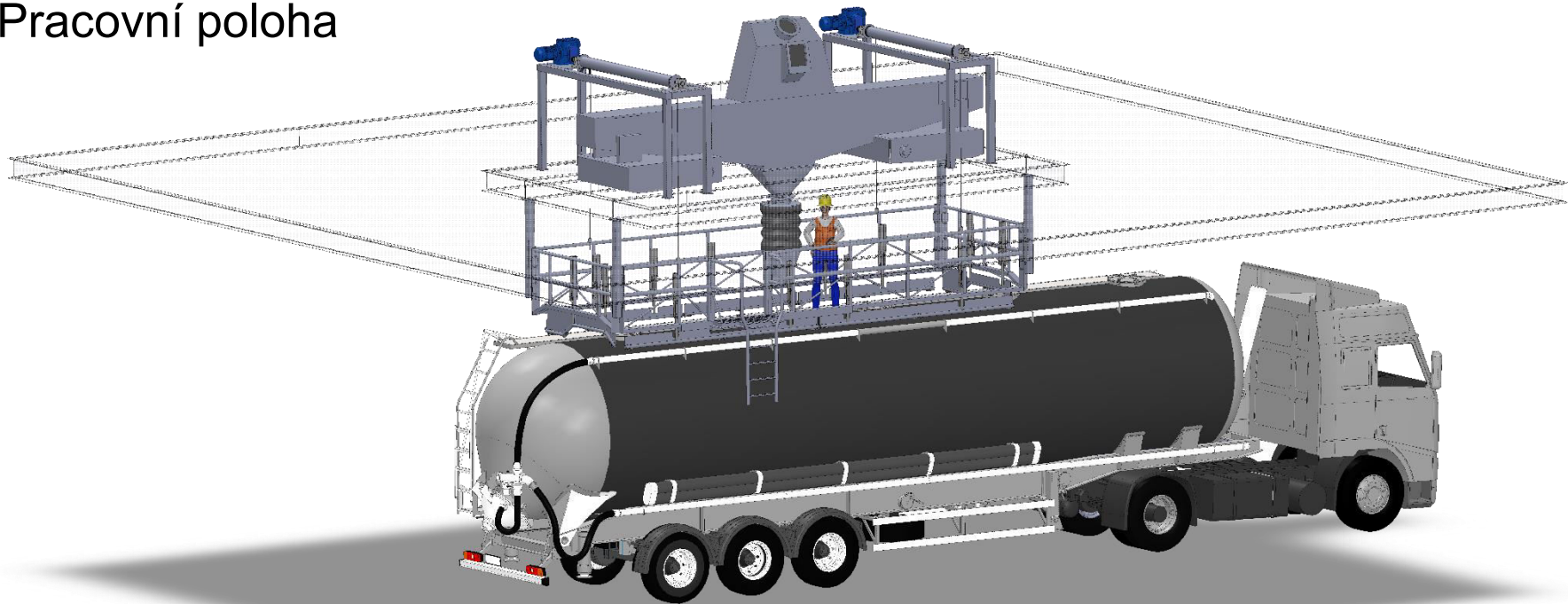



Provedení



Parkovací poloha

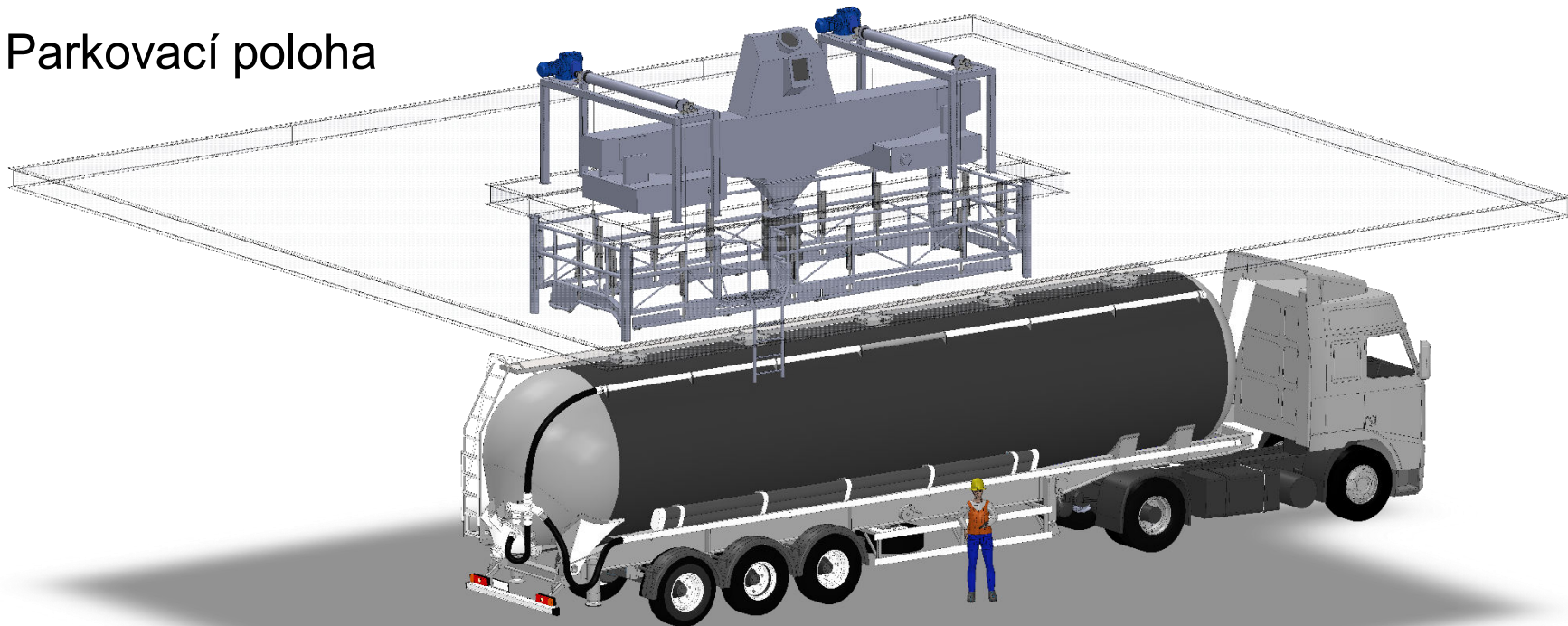



Vliv prostředí



A. Nová výstavba

B. Stávající provoz

1. krok Studie proveditelnosti

- sběr informací:
 - výška pracovního místa
 - typy obsluhovaných cisteren
 - podklady od stávající budovy expedice
 - způsob možného zavěšení / umístění
 - připomínky odpovědného pracovníka za provoz
- návrh vhodného technického řešení

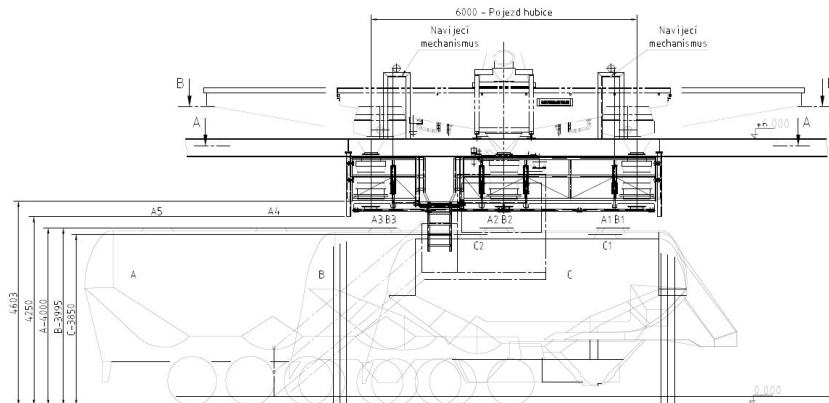

[Projekt bezpečnostního zábradlí](#)

2. krok Fyzická dodávka



Příklad realizace





Příklad realizace



Пříklad realizace





Kontakty

Ředitel společnosti:

Ing. Martin Macháček machacek@dsd-dostal.cz

Vedoucí výroby:

Ing. Roman Janovský janovsky@dsd-dostal.cz

Tel. +420 581 705 024

www.dsd-dostal.cz

info@dsd-dostal.cz

